

Commercial kitchen exhaust air

Helios ventilation systems for  
hot and greasy air.

**VDI 2052  
COMPLIANT**



Efficient  
solutions – for  
commercial  
kitchen exhaust  
air.



# Table of Contents

Planning tips and requirements	Page 4
Practical example	Page 6
<b>Extract air:</b>	
Roof fans	Page 10
Box fans	Page 12
– MegaBox	Page 13
– GigaBox	Page 14
<b>Supply air:</b>	
– Fresh air boxes	Page 16
– Rectangular duct fans	
– Circular duct fans	
<b>Regulation and control:</b>	
Manual and fully automated	Page 18

# Hot tip for pros.

## Helios ventilation systems for commercial kitchens:

- perfectly coordinated
- for the best air in kitchens and dining areas
- 100 % compliant with VDI 2052



# Complex requirements? Just the way we like it!

The room air in commercial kitchens is affected by heat, moisture, grease particles and, of course, odours. In order to remedy this situation, we have developed efficient solutions which ensure optimal air quality for any situation on site. Whether it is Helios roof fans or box fans – the polluted air is extracted directly at its source, safely and hygienically. The risk of hazardous grease fires is effectively minimised and unpleasant odours cannot reach other sections of the building. In addition, the ventilation also improves occupational safety, since good working conditions

are created in the premises.

Supply air and extract air systems are often required in commercial kitchens. In arithmetic terms, the kitchen exhaust air is a component of the extract air system in relation to the entire unit. In this respect, the utilisation unit must either be supplied with fresh air through backflow or a separate supply air system must be provided. It should be noted that air from areas which are potentially hygienically unsafe must never flow into the kitchen!

Important: In Germany, the rules of VDI 2052 apply to the ventilation of commercial kitchens. This also places strict requirements on ventilation technology.



**Your advantage:**  
**The kitchen pros from Helios – VD T120, GigaBox T120 and MegaBox – meet all these criteria 100 %!**



## ...in regards to the planning of the entire system:

- Suitable grease filters or separating elements made of non-combustible materials must be connected to or directly behind the extraction systems (hoods or ventilation ceilings). It must be possible to easily install and remove these for cleaning.
- Kitchen exhaust air ducts must not be interconnected or connected to other rooms with ventilation ducts. The combination of room air with the cooking zone extraction within the kitchen as well as the connection of multiple kitchen extraction hoods to one shared exhaust air duct is permitted.
- Exhaust air ducts must be made of non-combustible materials (building material class A1 or A2 pursuant to DIN 4102). From the point of exit from the kitchen, they must have fire resistance class L90 at least or be equipped with a damper with proof of use for this purpose.
- The regular maintenance and cleaning of ventilation systems in commercial kitchens is subject to special regulations. The German provisions of VDI 2052 apply for commercial kitchens with a total connected load of more than 25 kW of all kitchen appliances that give off heat and / or release moisture.
- Low negative pressure must be ensured in the kitchen so that odours and contaminated air cannot reach the dining area.

# Practical application example.

## Supply air

### Ventilation à la carte...

The optimally coordinated Helios system components ensure an individual supply air system – for almost any requirement and every flow rate.

<p><b>1</b></p> 	<p><b>Air filter</b> Rectangular duct filter</p> <ul style="list-style-type: none"> <li>With G4 or F7 filter</li> <li>Simple and fast filter replacement</li> <li>Can be mounted horizontally and vertically</li> </ul>	<p><b>2</b></p> 	<p><b>Supply air</b> Rectangular duct fan</p> <ul style="list-style-type: none"> <li>Various sizes and performance classes</li> <li>Also available with EC technology</li> <li>Sound insulated versions are available</li> </ul>
<p><b>3</b></p> 	<p><b>Air treatment</b> Heating element</p> <ul style="list-style-type: none"> <li>As a warm water or electric version</li> <li>Simple installation and connection</li> <li>Can also be switched in groups</li> </ul>	<p><b>4</b></p> 	<p><b>Operation</b> Supply air</p> <ul style="list-style-type: none"> <li>Various options</li> <li>Continuously variable speed controller or slide switch</li> <li>Elegant surface-mounted and flush-mounted models</li> </ul>

### ... or as a 5 course menu!

**1 2 3 4 + 5**



Supply air, heating, filter and supply air control system as well as separate extract air – everything in a single unit. The fresh air boxes Helios ALB provide for a pleasant indoor climate by supplying external intake air which is filtered and heated to the desired temperature. The provided touch control element controls the entire system!

- Optionally with electric or warm water heating
- Large cartridge filters for long cleaning intervals
- Integrated sound insulation for quiet operation
- Integrated control concept including control element for supply and extract air fans

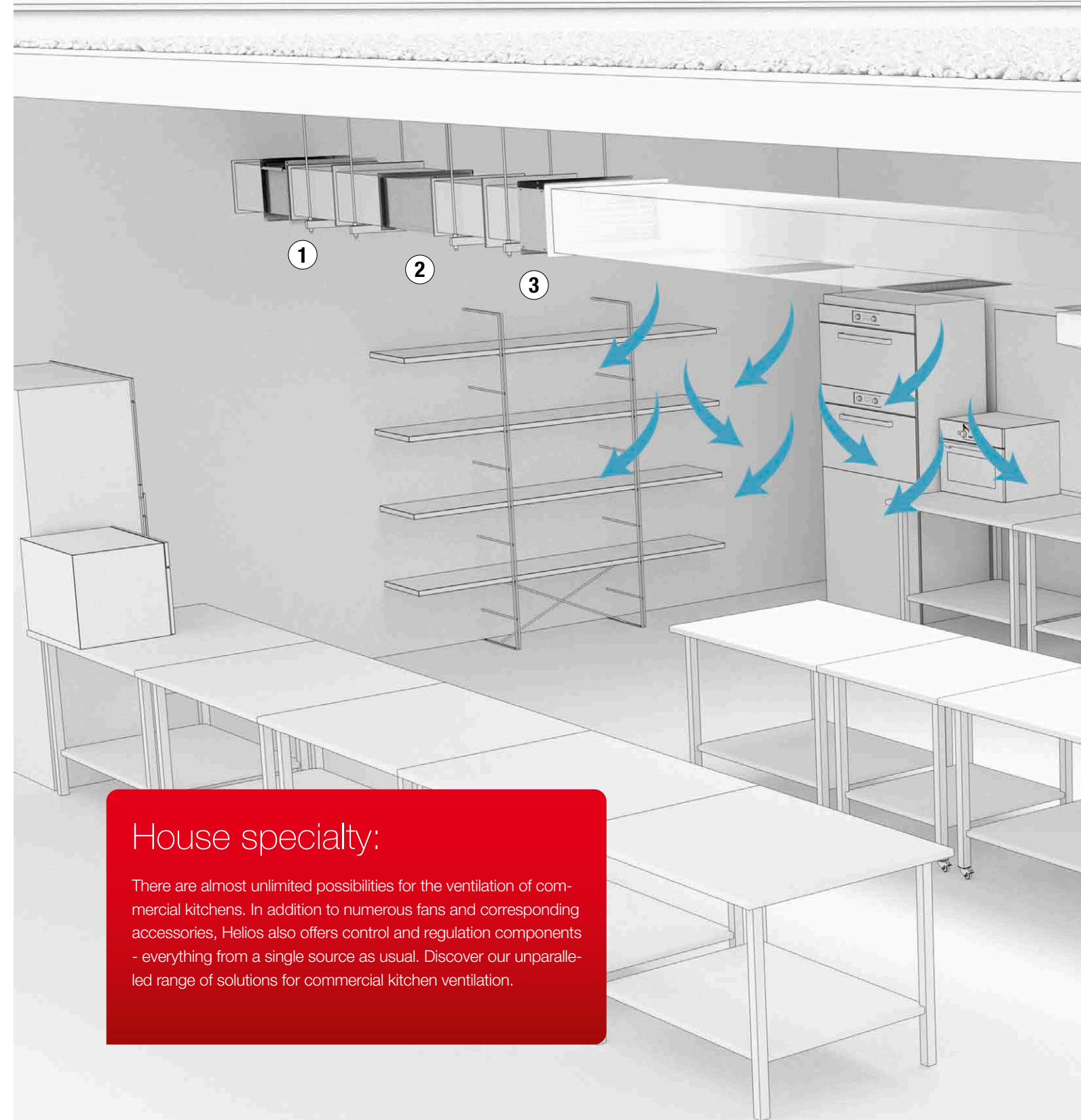

### House specialty:

There are almost unlimited possibilities for the ventilation of commercial kitchens. In addition to numerous fans and corresponding accessories, Helios also offers control and regulation components – everything from a single source as usual. Discover our unparalleled range of solutions for commercial kitchen ventilation.

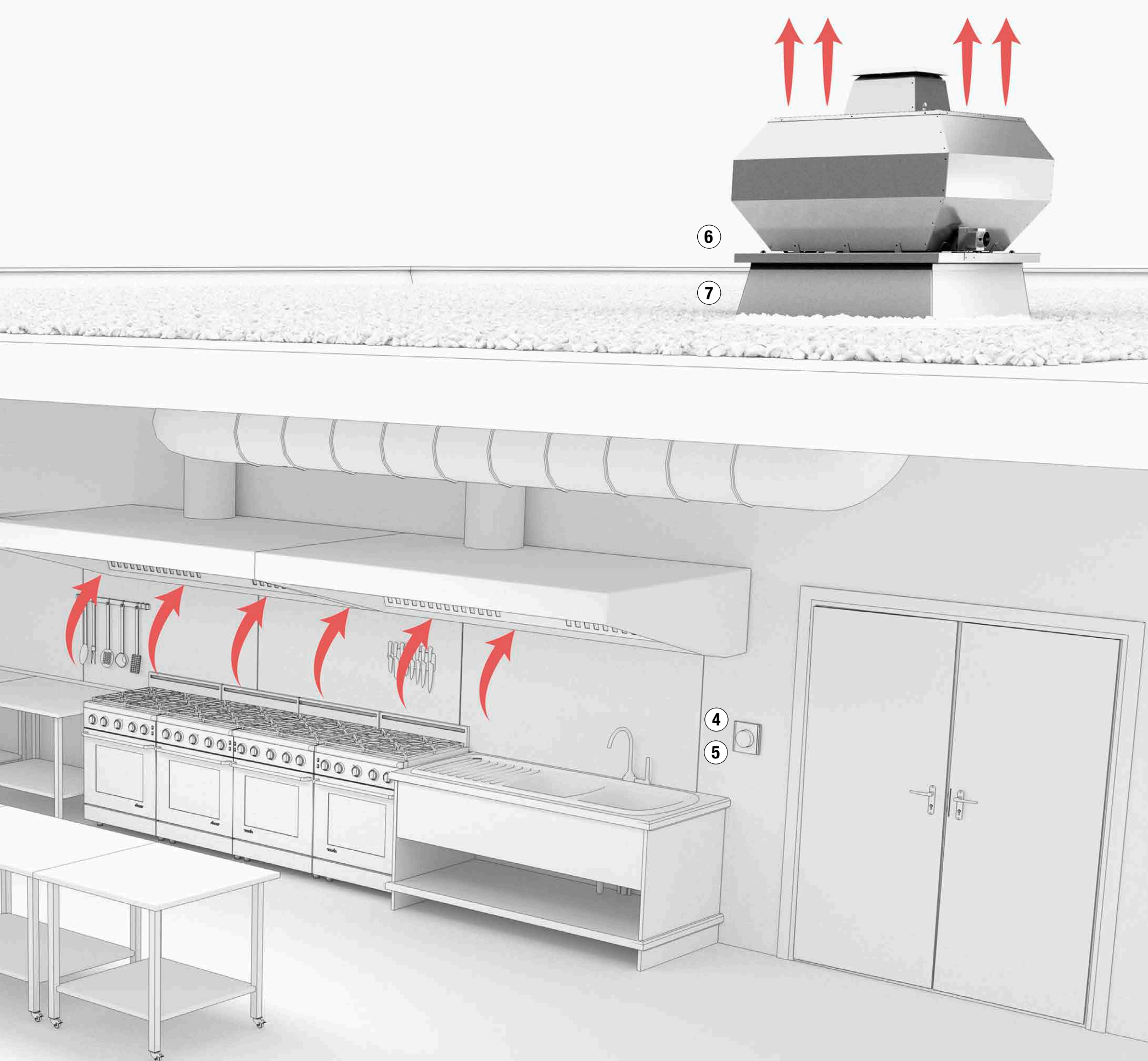

6

7

4

5

**Extract air**

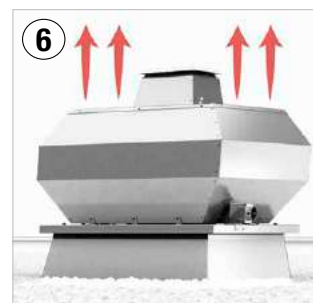

**Exhaust air**  
Roof fan T120

- Performance classes up to 24,500 m<sup>3</sup>/h
- Enclosed motor located outside of the air flow
- Robust quality – durable and reliable

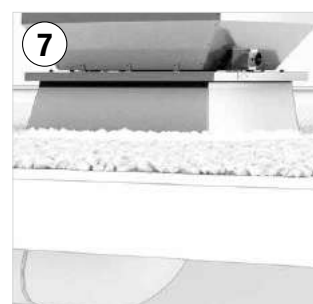

**Base**  
for roof installation

- Tailor-made solutions for all roof types
- Reduced costs and installation work
- Simple inspection and cleaning



**Operation**  
Extract air

- Various options
- Stepless speed controller or slide switch
- Elegant surface-mounted and flush-mounted models



**Control**  
Frequency inverter

- For controlling fan speeds
- Basic and comfort variants for all requirements
- Solutions with and without sine filters

**NEW**



## Roof fans VD T120:

Available sizes: Ø 315 – 710 mm  
Airflow range up to: 24,500 m<sup>3</sup>/h

### Highlights

- Ideal for conveying hot and greasy extract air in accordance with VDI 2052
- Reliable even under the most extreme conditions and continuous air flow temperatures of up to 120°C
- Motor located outside of the air stream
- Electrical connection to external isolator switch without casing dismantling







**Mechanical accessories**



■ **Flat roof base FDS**  
For the placement of roof fans on flat roofs. Corrosion-resistant GFK version with soundproofing insulation.

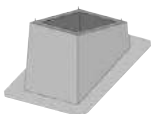

■ **Pitched roof base SDS**  
For placement on pitched roofs with up to 45° inclination. Made of galvanised steel sheet, with sound-insulated, 50 mm thick lining.



■ **Automatic backdraught shutter RVS**  
For the prevention of cold draughts when the fan is at a standstill. Automatic function through fan operation.



■ **Motor-driven backdraught shutter RVM**  
For vertical throughflow in any direction and with a mounted spring return motor (outside of air flow).



■ **Flanged flexible connector STSB F400**  
Flexible connector for installation between fan and duct system. Prevents structure-borne sound transmission.



■ **Flange ring FR**  
Made of galvanised steel sheet, for inlet side duct connection. Can be directly screwed to the fan base plate.



■ **Base silencer SSD**  
For inlet-side sound insulation. Average insulation value 15 dB. All metal parts made of galvanised steel sheet.



■ **Corrugated roof base WDS**  
For the placement of roof fans on corrugated roofs. Weather-resistant and non-corrosive design.

**Note:** Regulation and control components can be found on page 18.

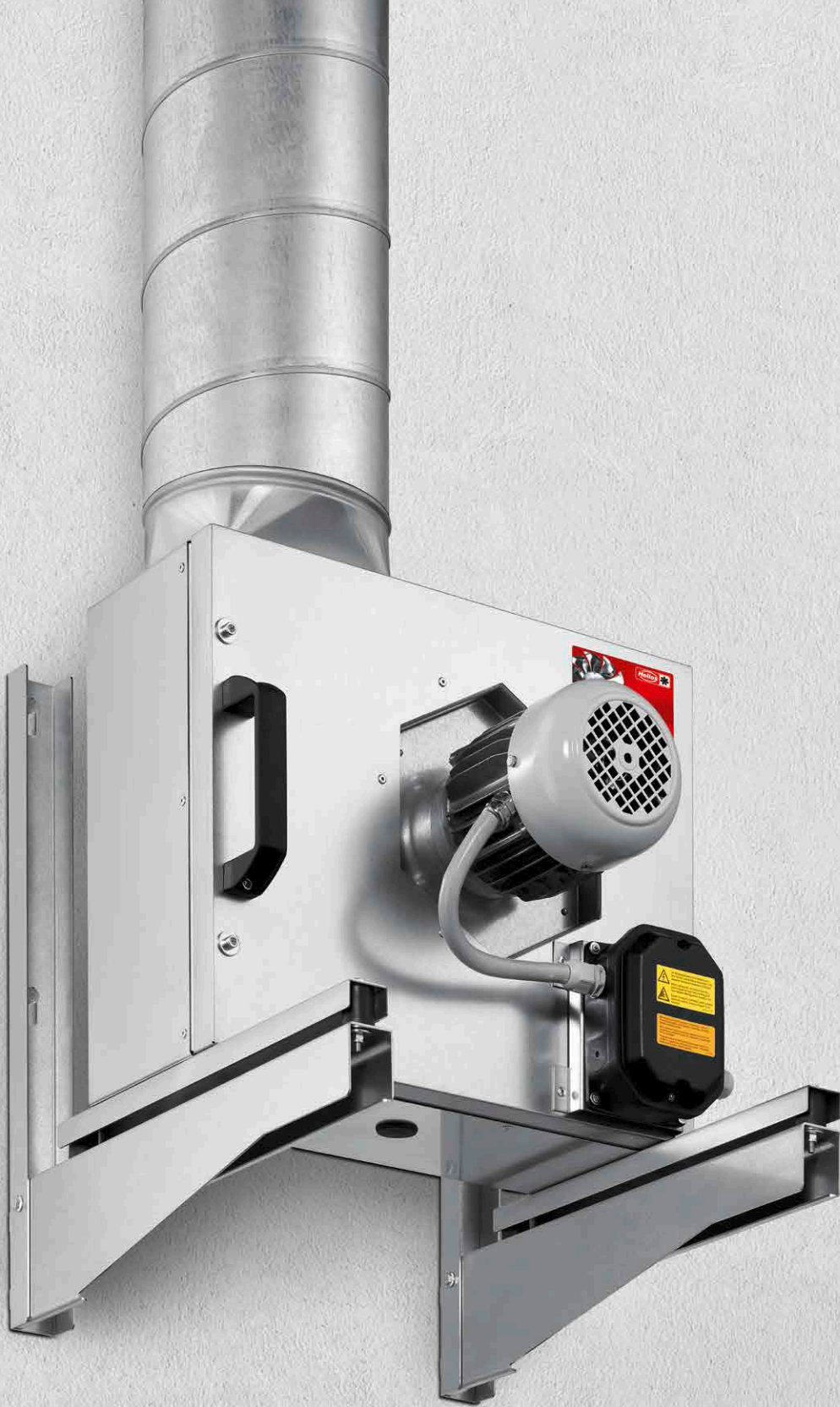

# Box fans

## MegaBox:

### Highlights

- Ideal for conveying hot and greasy extract air in accordance with VDI 2052
- Retractable fan unit guarantees simple cleaning and maintenance
- Reliable even under the most extreme conditions and continuous air flow temperatures of up to 120°C
- Speed controllable IEC flange motor located outside of the air flow – includes self-cooling and thermal overload protection
- Helios MegaBoxes with EC drive technology impress with continuously variable controllability



Available sizes: Ø 225 – 400 mm  
Airflow range up to: 7,500 m<sup>3</sup>/h

### Mechanical accessories



- **Wall bracket MB-WK**  
Bracket for wall mounting, made of galvanised steel sheet.



- **Flexible sleeve FM**  
For installation between the fan and duct system. Prevents structure-borne sound transmission and compensates for mounting tolerances.

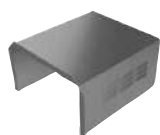

- **Weather protection cover MB-WSD**  
For protected outdoor installation. Made of galvanised steel sheet, fastening above the motor.

**Note:** Regulation and control components can be found on page 18.

# Box fans

## GigaBox:



### Highlights

- Ideal for conveying hot and greasy extract air in accordance with VDI 2052
- Motor located outside of the air flow
- Inspection cover with handle – easily removable for cleaning and maintenance
- Complete motor-impeller unit can be removed without dismantling the system components
- Reliable even under the most extreme conditions and continuous air flow temperatures of up to 120 °C
- GigaBox T120 types with EC technology are also optionally available – these have continuously variable controls

**Available sizes:** Ø 250 – 710 mm  
**Airflow range up to:** 18,360 m<sup>3</sup>/h

### Mechanical accessories



- **Vibration dampers SDD-U**  
For indoor installation.



- **Weather protection grille GB-WSG**  
For outlet-side coverage, made of galvanised steel sheet.



- **Wall bracket GB-WK**  
Bracket for wall mounting, made of galvanised steel sheet.



- **Weather protection cover MB-WSD**  
For protected outdoor installation. Made of galvanised steel sheet, fastening above the motor.

**Note:** Regulation and control components can be found on page 18.





Other Helios supply air fans available on [HeliosSelect.de!](https://www.heliosselect.de)

## Suitable supply air fans

In addition to the aforementioned extract air fans, Helios offers various solutions for quiet and energy-saving air supply fans for integrated ventilation systems in commercial kitchens. From simple, installation-friendly supply air fans through to intelligent complete solutions including pre-heating and integrated air filtration, the right solution is available for almost any requirement.

### Fresh air boxes

**Best indoor climate due to pre-heated, filtered supply air.  
All-in-One up to 6,200 m<sup>3</sup>/h.**

Supply air, heating and filter in one single unit. For direct insertion in round duct and rectangular duct runs. ALB provide for a pleasant indoor climate by supplying external intake air which is filtered and heated to the pre-set temperature.

- Alternatively with electric or warm water heating
- Large cartridge filters for long cleaning intervals
- Integrated control concept including control element for supply and extract air fans
- Integrated sound insulation for quiet operation



**Available series:**  
ALB (EC)

## Rectangular duct fans

**The all-rounders for rectangular duct systems.  
Various solutions up to 14,400 m<sup>3</sup>/h.**

Powerful, efficient and demand-oriented, fresh air is brought to every corner of the building. Nothing is left to be desired when choosing between AC or economical EC technology, high-quality sound insulation and all common connection dimensions.

- Wide range for all duct dimensions
- In forward and backward curved versions
- Maximum installation flexibility and ease of installation
- Efficient high-performance impellers with optimal efficiency levels



**Available series:**  
KV, (S)KRW (EC) and (S)KRD (EC)

## InlineVent circular duct fans

**An all-round concept.  
Proven powerhouses up to 2,000 m<sup>3</sup>/h.**

InlineVent circular duct fans combine the performance characteristics of centrifugal fans with the advantages of axial design. The linear flow pattern allows direct insertion in duct systems as well as easy, cost-effective installation.

- Complete type diversity in all sizes
- All series also available with EC technology
- Compact solutions for space-saving installation in ducting
- Robust construction in professional quality



**Available series:**  
RR (EC), MV (EC) and SVR (EC)

## Acoustic Line circular duct fans

**Incredible power.  
Sound-insulated solutions up to 4,700 m<sup>3</sup>/h.**

Acoustic Line circular duct fans are characterised by the lowest noise levels and thus they are also suitable for noise sensitive environments. This is achieved by using particularly low-noise high performance impellers and highly efficient insulation.

- All casings with 50 mm mineral wool lining
- Retractable motor-impeller unit as standard
- SilentBox SB with highest volume and pressure performance
- SlimVent SVS with lowest installation height and flexible installation in any position



**Available series:**  
SB (EC) and SVS (EC)



# All set?

## Manual control:

### Isolator switch/main switch



#### ■ Isolator switch/main switch RHS 3+1

"0" position can be locked with a padlock. In accordance with DIN EN 60204 p.1/VDE 0113-1. Plastic casing for surface-mounted installation. 3-pole with auxiliary contact, for single-speed and speed-controlled fans.



#### ■ Isolator switch/main switch RHS 6+2

"0" position can be locked with a padlock. In accordance with DIN EN 60204 p.1/VDE 0113-1. Plastic casing for surface-mounted installation. 6-pole with 2 auxiliary contacts, for all pole-changing fans.

### Speed control



#### ■ Speed switch DS 2

Speed switch and on/off switch for two-speed three-phase current fans in  $\Upsilon/\Delta$  connection. Grey plastic casing for surface-mounting.



#### ■ Transformer speed controller TSW

For one or more alternating current fans.



#### ■ Transformer speed control TSD

For one or more 3~ fans.



#### ■ Transformer speed controller with motor protection circuit breaker

**MWS:** Five-step speed controller with integrated triggering device for 230 V, 1~ fans.



**RDS:** Five-step speed controller with integrated thermal contact triggering device for 3~, 400 V three-phase current fans.



#### ■ Speed control transformer TSSD

Two integral transformers with foot rails and terminal block for 5 voltage taps. Connection in V circuit.



### For EC fans or frequency inverters:



#### ■ Potentiometer PU/PA

For direct control of fans with a potentiometer input. With release switch and LED display.



#### ■ Three level switch SU/SA

For three level controlling of frequency inverters with a 0–10 V DC control input.



# As required and fully automated:

## Control in conjunction with



### ■ Universal control system EUR 6 C

For control of central/ventilation systems or for the stepless control of one or more speed-controllable single phase fans.



### ■ Frequency inverter FU-BS

Frequency inverter with integrated, all-pole effective sine filter. Speed specification via the 0–10 V control signal.



### ■ Frequency inverter FU-CS

Frequency inverter FU-CS in comfort design with integrated, all-pole effective sine filter. For controlling the speed of one or more fans.



### For EC fans:



### ■ Universal control system EUR EC

For continuously variable control or regulation of single and three-phase EC fans



## Intelligent sensors



### ■ Room temperature sensor LTR 40

Measurement range 0.5 - 40 °C.  
For wall installation.



### ■ Electronic temperature controller ETR

The temperature controller is freely adjustable within the sensor measurement ranges, optionally in heating or cooling function, with adjustable minimum air shut-off. Temperature control range lies between -50 and +150 °C.



### ■ Electronic differential pressure controller EDR

Adjustable pressure ranges: 0-1000 Pa,  
0-500 Pa, 0-300 Pa, 0-200 Pa.



**Helios Ventilatoren GmbH + Co KG** · Lupfenstraße 8 · 78056 Villingen-Schwenningen · Germany  
Tel. + 49 (0) 77 20 / 606 - 0 · Fax + 49 (0) 77 20 / 606 - 166 · [info@heliosventilatoren.de](mailto:info@heliosventilatoren.de) · [www.heliosventilatoren.de](http://www.heliosventilatoren.de)  
Export: Fax + 49 (0) 77 20 / 606 - 257 · [export@heliosventilatoren.de](mailto:export@heliosventilatoren.de)

---

KWL® is a registered trademark of Helios Ventilatoren GmbH + Co KG. Copyright ©: Helios Ventilatoren GmbH + Co KG, VS-Schwenningen.  
Certified according to ISO 9001/2015. Subject to technical modifications. Illustrations and information are non-binding. Document no. 10210.844/11.21